

# WAYKEN®

Industrial Sewing &  
Cutting Machine Spare Parts

CUTTING MACHINE SPARE PARTS

裁布機零件系列

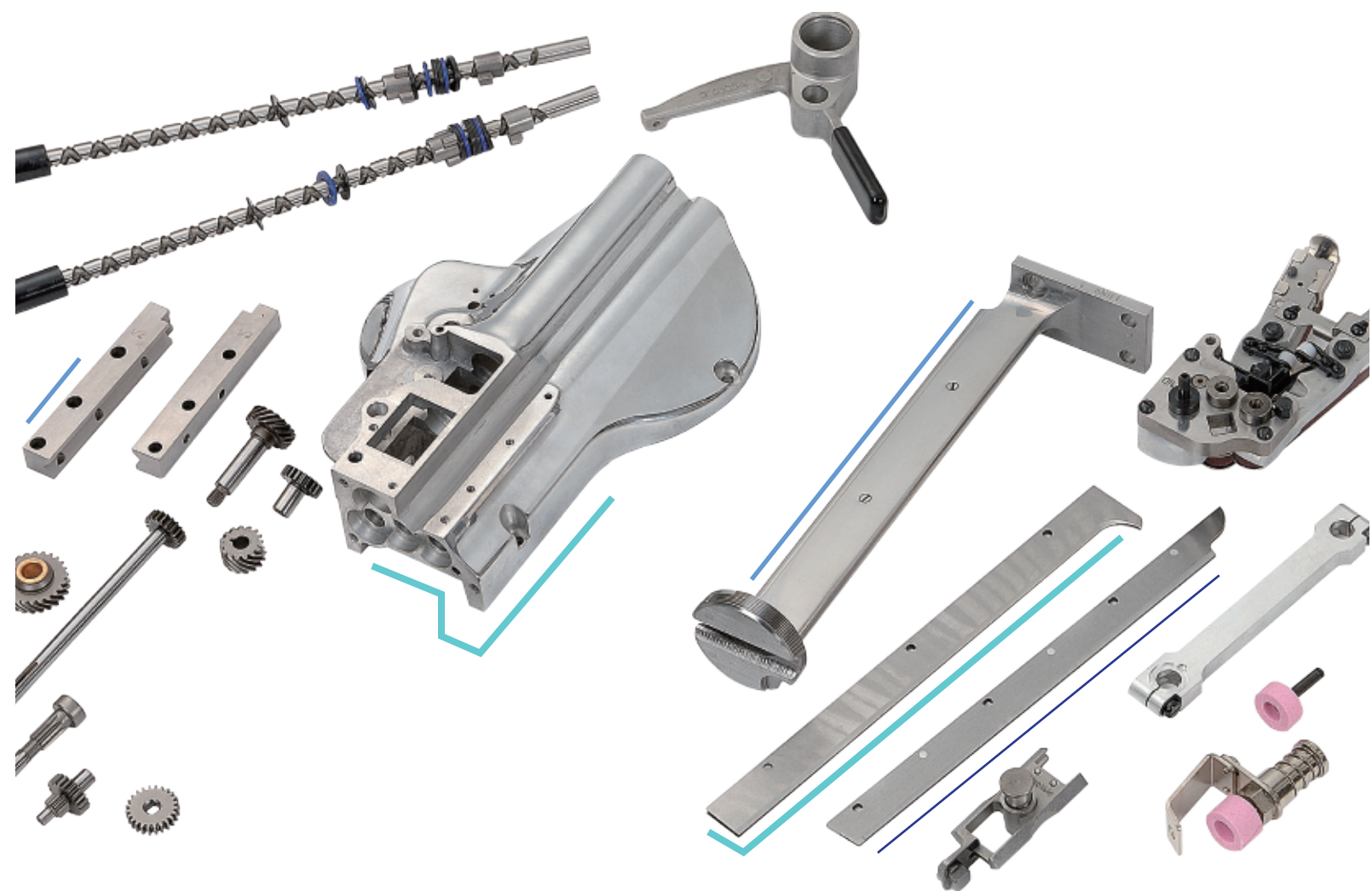

# CUTTING MACHINE SPARE PARTS

FOR EASTMAN SERIES EASTMAN裁布機零件系列

4C1-99	SHARPENER HOLD-DOWN, NUT	磨刀器固定螺母
4C1-150	SHARPENER HOLD-DOWN, NUT	磨刀器固定螺母
4C1-179	FRONT-TO-REAR BRARING, NUT	電機固定螺母
4C2-2	PLATE BOLT, NUT	底盤螺母
20C3-38	FRONT TO REAR BEARING, SCREW	電機螺栓
20C3-39	FRONT TO REAR BEARING, SCREW	電機螺栓
20C13-96	STANDARD-TO-BEARONG, SCREW	電機螺栓
24C4	PLATE, BOLT	電機螺栓
4C1-145	SHAFT, LOCKNUT	鎖軸螺母
4C2-87	CLUTCH ,NUT	離合器螺母
8C5-10	AUTOMATIC STITCH INSULATION	磨刀器固定螺母
8C12-4	LEAD WIRE INSULATION	磨刀器固定螺母
10C1-41	FAN ROTOR	散熱風扇
12C1-12	LOADING SPRING, WASHER	底盤螺母
12C1-32	LOCK, WASHER	外齒墊圈
13C1-9	TUNING KNOB	手動旋鈕
18C6-16	RETAINING RING	電機螺栓
22C1-24	CARRYING HANDLE	提把
30C1-8	DUST CAP	鎖軸螺母
34C1-51	CLUTCH, SPRING	電機後蓋彈簧
47C4-79	TERMINAL	接線端子
47C4-80	TERMINAL	接線端子
53C7-35	FAN COVER	風扇後蓋
73C7-121	TERMINAL WIRE TUBING	護線套管
90C1-146	REAR BEARING HOUSING	電機後罩
90C6-46	REAR BALL BEARING	6201滾珠軸承
254C1	CABLE TIE 4"	扎帶
300C12-6	SCREW, ROUND HEAD	8-32*1/2半圓頭螺釘
301C8-1	SCREW, #4-40 X 1/2 FILLISTER HEAD	4-40*1/2球面圓柱頭螺釘
301C12-3	SCREW, #8-32 X 3/8 FILLISTER HEAD	8-30*3/8球面圓柱頭螺釘
305C8-1	SCREW,BINDING HEAD	4-40*1/4卷頭螺釘
305C10-1	SCREW,BINDING HEAD	6-32*1/4卷頭螺釘
597C2-15	CUTOUT ASSY 50 CYCLE 3000RPM	風扇後蓋
783C1-3	GROUNDING WIRE ASS'Y	接地線
4C1-111	OPEARING HANDLE LOCK NUT	手柄螺母
4C1-132	CRANK BELL BEARING LOCK NUT	圓曲柄軸承蓋
4C1-190	LOCK NUT FOR SHAFT	曲柄軸螺母
4C2-91	NUT FOR GUIDE SCREW	導板調整螺母
4C2-110	STOP NUT	電容器止動螺母
4C3-8	GUIDE ADJUSTMENT NUT	導板螺母
11C12-92	SHAFT FOR BALL BEARING	圓曲柄軸
12C1-21	SHAKEPROOF WASHER	內齒彈性墊圈
12C1-24	KNIFE LOCK WASHER	壓力墊片
12C10-2	WASHER	墊圈
12C15-14	GUIDE WASHER	墊圈
12C15-53	CONNECTING ROD WASHER	連桿墊圈
15C13-23	STUD,UPPER	雙頭螺栓
15C13-34	STUD, LOWER L.H. MOUNTING	下左雙頭螺栓
15C13-39	STUD, LOWER R.H. MOUNTING	下右雙頭螺栓
17C4-6	WRIST PIN	腕銷
18C6-79	LOCK RING	油屏螺母
18C6-80	O-RING	油屏墊片
20C5-17	CONNECTING ROD CLAMP SCREW	傳動桿緊固螺絲
20C12-62	FRONT HOUSING PLUG SCREW	螺釘

# CUTTING MACHINE SPARE PARTS

## EASTMAN裁布機零件系列 FOR EASTMAN SERIES

20C12-79	SCREW FOR HANDLE BRACKET	手柄托架螺絲
24C1-3	KNIFE LOCK BOLT	刀片鎖緊螺絲
34C10-142	SPRING FOR CAPACITOR	電容彈簧片
52C5-235	SWITCH PLATE (SINGLE-SPEED)	下左雙頭螺柱
53C6-2	OILER TUBE COVER	油槽蓋
53C11-91	CAPACITOR COVER	電容器架
54C4-32	WRIST PIN PLUG	腕銷栓
62C1-140	HANDLE BRACKET	把手托架
71C3-18	FRONT BALL BEARING RETAINER	前軸承蓋
73C7-203	OIL TUBE , CLEAR	導油管
73C7-204	OILER TUBE	油槽
85C1-45	CRANK 5 - 1-1/2" STROKE	圓曲柄1 1/2冲程
90C6-38	FRONT BALL BEARING	6203滾珠軸承
91C4-25	RIVET CROSSHEAD	鉚釘
191C1-21	CROSS HEAD FELT PAD	滑座油墊
191C1-38	WRIST PIN FELT PAD	腕銷油芯
191C1-42	OIL FELT WICKING, LONG	長油芯
191C1-43	OIL FELT WICKING, SHORT	短油芯
191C1-45	OIL FELT WICKING .187DIA X .44	主油芯
201C1-11	EYELET	導油管
300C3-2	SCREW	2-56*1/8半圓頭螺釘
302C8-2	SCREW, FLAT HEAD #4-40 X 3/4	4-40*3/4沉頭螺釘
302C10-4	SCREW, #6-32 X 5/16 FLAT HEAD	6-32*5/16沉頭螺釘
307C18-1	SCREW	手柄托架固定螺絲
308C12-1	SCREW, #8-32 X 3/8 SOCKET HEAD	8-32*3/8內六角螺釘
308C14-1	GUIDE HOLD DOWN SCREW	導板內六角螺釘
309C15-5	GUIDE ADJUSTMENT SCREW	導板調整螺絲
525C1-5	L.H. & R.H. GUIDES 1-1/2 STROKE	1 1/2冲程導軌
531C1-53	OPERATING HANDLE	手柄組
579C2-17	CROSS HEAD (W/ WRIST,PIN,WASHER,BOLT)	滑座組
580C1-198	SWITCH-SINGLE-SPEED-1&3-PHASE	2-56*1/8半圓頭螺釘
607C1-35	OILING DEVICE	油槽組
664C1-4	CONNECTING ROD 1 1/2 STROKE	連桿組 冲程1 1/2
706C1-4	CAPACITOR 629 110V	手柄托架固定螺絲
706C1-5	CAPACITOR 629 220V	8-32*3/8內六角螺釘
4C1-149	NUT, ELASTIC	螺軸止動螺母
4C1-161	NUT, SELF LOCK	鎖托架止動螺母
4C2-112	L.H. NUT FOR SCREW SHAFT	螺軸右旋螺母
4C2-113	R.H. NUT FOR SCREW SHAFT	螺軸左旋螺母
5C5-16	COLLAR, LOWER	螺軸固定墊圈
11C12-54	SHAFT FOR CAM	放鬆桿彈簧銷
12C15-57	SPRING WASHER FOR RELEASE LEVER	放鬆桿彈性墊圈
12C15-69	WASHER FOR LOCK BRACKET	護刀桿墊片
12C15-74	WASHER, FLAT	軸承厚墊片
12C15-91	THRUST WASHER, UPPER NUT	軸承薄墊片
17C15-106	ROLL PIN FOR COLLAR	彈性圓柱銷
20C4-17	PRESSURE FOOT LEVER SCREW	壓腳柄螺絲
20C12-13	CAM SHAFT SPRING SCREW	彈簧螺絲
20C12-113	SCREW FOR LATCH	撥叉螺絲
20C12-117	SCREW FOR PRESSURE FOOT SHOE	壓腳螺絲
20C12-156	SCREW FOR RELEASE LEVER	放鬆桿螺絲
20C12-137	SCREW FOR KNIFE GUARD LOCK	鎖托架螺絲
22C3-2	LIFT HANDLE FOR KNIFE GUARD LOCK	護刀桿把手
34C1-20	TENSION SPRING	蝸旋彈簧

# CUTTING MACHINE SPARE PARTS

## FOR EASTMAN SERIES EASTMAN裁布機零件系列

34C8-12	SPRING FOR PRESSURE FOOT LOCK	鎖托架彈簧
34C10-179	SPRING FOR PRESSURE FOOT LEVER	壓腳柄彈簧
34C10-107	SPRING FOR LATCH	撥叉彈簧
53C11-72	COVER FOR CAM	彈簧螺絲
53C11-103	VINYL COVER FOR HANDLE	手柄護套
55C4-49	SPACER FOR KNIFE GUARD LOCK BRACKET	厚薄規
68C1-192	PRESSURE FOOT SHOE, ALL STROKES	壓腳
71C3-15	THRUST BALL BEARING	推力軸承
86C7-34	CAP FOR TUBE	管帽
90C4-47	BEARING FOR CAM SHAFT	中間齒輪含油軸承
97C3-35	LATCH FOR CAM	撥叉
147C1-26	EXTENSION FOR SCREW SHAFT	螺軸延長
171C1-16	LOCK (ONLY) FOR PRESSURE FOOT	壓腳鎖
300C10-1	SCREW, #6-32 X 3/16 ROUND HEAD	6-32*3/16半圓頭螺釘
300C10-4	SCREW, #6-32 X 3/8 ROUND HEAD	6-32*3/8半圓頭螺釘
302C10-8	SCREW, #6-32 X 3/4 FLAT HEAD	6-32*3/4沉頭螺釘
309C15-7	SET SCREW FOR CAM	彈簧鎖緊固定螺絲
553C1-7	PRESSURE FOOT LOCK BRACKET COMPLETE	護刀桿托架組
553C1-8	PRESSURE FOOT LOCK BRACKET ONLY	護刀桿托架
605C1-36	PRESSURE FOOT ROD 7"-8" KNIFE	8"護刀杆組件
605C1-37	PRESSURE FOOT ROD 9"-10" KNIFE	10"護刀杆組件
621C1-7	RELEASE LEVER WITH CAM	放鬆桿連凸輪
683C1-17	PREAAURE FOOT LEVER	壓腳手柄組
713C4-4	SCREW SHAFT W/EXTENSION R&H HEAD	5-8"螺軸組件
713C4-5	NUTS 5-8"(713C-4) / NUTS 9-10"(713C-5)	9-10"螺軸組件
732C1-11	SHARPENER HOUSING W/BUSHING,TUBES ONLY	磨刀器罩(連襯和管子)5-8"
732C1-12	5"- 8" KNIFE(732C1-11) / 9"- 10" KNIFE(732C1-12)	磨刀器罩(連襯和管子)9-10"
65C1-77	ROD FOR PRESS FOOT 5"-8"	8"護刀杆
65C1-75	ROD FOR PRESS FOOT 9"&10"	10"護刀杆
11C12-95	SCREW SHAFT ONLY 5" - 8"	5-8"螺軸
11C12-96	SCREW SHAFT ONLY 9" -10"	9-10"螺軸
4C2-85	R.H. FOLLOWER NUT	右方軸螺母
4C2-86	L.H. FOLLOWER NUT	左方軸螺母
11C12-58	R.H. SQUARE SHAFT 5"-8" KNIFE	右方軸8"
11C12-59	R.H. SQUARE SHAFT 9"-10" KNIFE	右方軸10"
11C12-56	L.H. SQUARE SHAFT 5"-8" KNIFE	左方軸8"
11C12-57	L.H. SQUARE SHAFT 9"-10" KNIFE	左方軸10"
11C12-64	SHAFT FOR CRANK	曲柄軸
12C11-74	THRUST WASHER	耐磨墊片
12C15-29	THRUST WASHER	斜齒輪墊片
12C15-30	THRUST WASHER FOR BOTTOM PLATE	半圓墊片
17C15-78	PIN FOR BELL CRANK	曲柄銷
17C15-103	ROLL PIN FOR PUSH ROD	推杆彈性圓柱銷
17C15-113	SPREADER PIN	推展銷
18C6-81	RETAINING RING FOR SHAFT	曲柄軸卡簧
18C6-26	RETAINING RING FOR BELL CRANK	曲柄卡簧
34C10-89	SPRING FOR BELL CRANK	曲柄彈簧
55C4-41	SPACER BELL CRANK	曲柄軸承襯套
62C16-151	SHARPENER HOUSING (ONLY)	耐磨墊片
65C6-75	PUSH ROD	推杆
71C1-10	OIL RETAINER-IDLER GEAR	貯油器
73C7-46	TUBE FOR SQUARE SHAFT 5"-8' KNIFE	8"方軸管
73C7-47	TUBE FOR SQUARE SHAFT 9"-10" KNIFE	10"方軸管
73C7-48	TUBE FOR SCREW SHAFT 5"-8" KNIFE	8"螺軸管

# CUTTING MACHINE SPARE PARTS

## EASTMAN裁布機零件系列 FOR EASTMAN SERIES

73C7-49	TUBE FOR SCREW SHAFT 9"-10" KNIFE	10"螺軸管
79C12-163	BOTTOM PLATE, SHARPENER HOUSING	磨刀器底盤
85C3-6	CRANK BELL (ONLY)	曲柄
87C3-8	SPIRAL GEAR	螺旋齒輪
87C3-44	SPUR GEAR	磨刀器底盤齒輪
87C3-53	GEAR AND SHAFT	曲柄傳動齒輪軸
90C4-29	BEARING FOR DRIVE SHAFT (LOWER)	傳動含油軸承
90C4-33	BEARING FOR GEAR	方軸含油軸承
90C4-34	BEARING FOR BELL CRANK	曲柄含油軸承
90C4-42	BEARING FOR DRIVE SHAFT	傳動含油軸承
90C4-48	BEARING FOR DRIVE SHAFT (UPPER)	傳動含油軸承
90C4-58	BEARING FOR SCREW SHAFT	螺軸含油軸承
90C6-24	BALL BEARING FOR CRANK	608滾珠軸承
142C1-7	KEY FOR GEAR.	傳動銷
300C7-1	SCREW, #4-36 X 1/8 ROUND HEAD	4-36*1/8半圓頭螺釘
302C10-6	SCREW, #6-32 X 1/2 FLAT HEAD	6-32*1/2沉頭螺釘
302C12-3	SCREW, #8-32 X 3/8 FLAT HEAD	8-32*3/8沉頭螺釘
584C2-3	BELLCRANK WITH PIN & BEARING(ONLY)	方軸含油軸承
584C3-16	BELLCRANK COMPLETE WITH LEVER	曲柄組含把手
602C1-9	DRIVER PULLEY WITH DRIVER	磨擦輪
627C1-10	IDLER GEAR & BUSHING	惰輪
716C1-12	DRIVER SHAFT WITH GEAR	磨刀器傳動軸
727C1-6	OIL PAD & HOLDER	油墊托盤
17C15-82	RIVET	插銷
300C7-2	SCREW, #4-36 X 3/16 ROUND HEAD	4-36*3/16半圓頭螺釘
1C13-13	NUT	調距套筒
53C11-109	VINYL COVER FOR CRANK	曲柄膠柄
4C1-189	JAM NUT,#8-32	鎖緊螺母
4C2-63	NUT FOR SHARPENER SHOE SCREW	磨刀靴螺母
12C15-93	WASHER, SHOE	磨擦輪
20C6-25	ADJUSTING SCREW	限位調整螺絲
20C12-143	SCREW FOR CLAMPING ARM	夾臂螺絲
20C12-153	SCREW FOR SHARPENER SHOE	磨刀靴螺絲
21C14-14	BUSHING FOR SHARPENER SHOE	磨刀靴襯套
34C10-45	SPRING FOR PULLEY SLIDE	滑輪彈簧
34C10-123	SPRING FOR ARM	夾臂彈簧
34C10-148	L.H. SHARPENER SHOE SPRING	左磨刀靴彈簧
34C10-149	R.H. SHARPENER SHOE SPRING	右磨刀靴彈簧
35C7-28	CLAMPING ARM FOR SHOE	磨刀靴夾臂
53C4-78	GEAR COVER	齒輪軸蓋
54C4-35	OIL HOLE PLUG	齒輪潤滑油蓋
62C6-31	BRACKET, LOWER GEAR	齒輪托架
70C4-32	GUIDE BACK OF STANDARD	刀夾後導板
79C12-219	WEAR PLATE	耐磨護板
87C3-50	GEAR ON SCREW SHAFT	螺軸齒輪
87C5-13	INTERMEDIATE GEAR	中間齒輪
90C4-51	BEARING FOR SCREW SHAFT	螺軸(下部)含油軸承
90C4-59	BEARING FOR SHAFT EXTENSION	延長軸含油軸承
147C1-28	R.H. SHAFT EXTENSION	右方軸延長軸
147C1-29	L.H. SHAFT EXTENSION	左方軸延長軸
152C1-19	FRONT PULLEY FOR BELT	滑輪
209C1	NEOPRENE BAND FOR PULLY	橡皮圈
300C7-3	SCREW, #4-36 X 1/4 ROUND HEAD	4-36*1/4半圓頭螺釘
300C10-2	SCREW, #6-32 X 1/4 ROUND HEAD	6-32*1/4半圓頭螺釘



# CUTTING MACHINE SPARE PARTS

## FOR EASTMAN SERIES EASTMAN裁布機零件系列

300C10-6	SCREW, #6-32 X 1/2 ROUND HEAD	6-32*1/2半圓頭螺釘
301C7-2	SCREW, #4-36 X 3/16 FILLISTER HEAD	4-36*3/16球面圓柱頭螺釘
301C10-3	SCREW, #6-32 X 3/8 FILLISTER HEAD	4-36*3/8球面圓柱頭螺釘
309C12-2	STOP SCREW, L.H. SHOE	左磨刀靴調整螺絲
712C1	R.H. SLIDE WITH PULLEY	右滑輪
712C1-1	L.H. SLIDE WITH PULLEY	左滑輪
715C1-19	LOWER GEAR BRACKET WITH COVER, SCREW, PLATE 5 - 13"	下齒輪托架和蓋子
715C1-23	LOWER GEAR BRACKET (COMPLETE)	下齒輪托架(全套)
728C1-5	STABILIZER ASSEMBLY	定位輪架
743C1-28	R.H. PRE-SET SHARPENER SHOE (ONLY)	右磨刀靴
743C1-29	L.H. PRE-SET SHARPENER SHOE (ONLY)	左磨刀靴
820C1-7	L.H. COMPLETE SHOE ASSEMBLY,	左磨刀靴組件
820C1-8	R.H. COMPLETE SHOE ASSEMBLY,	右磨刀靴組件
12C1-35	LOCK WASHER, #8 .	外齒墊圈
17C1-4	TAPER PIN #0 X 3/4	圓柱銷
17C6-9	HINGE PIN	鉸鍊
20C5-12	CLAMP SCREW FOR ROLLERS	膠輪夾緊螺絲
20C12-19	KNIFE SLIDE SCREW	刀夾螺絲
20C13-51	HINGE PIN CLAMP SCREW	鉸鍊夾緊螺絲
34C1-57	PLATE WING TENSION SPRING	底盤翼彈簧
60C1-55	PLATE WING (FOR SMALL PLATES)	底盤翼(小底盤專用)
60C1-56	PLATE WING (FOR LARGE PLATES)	底盤翼(大底盤專用)
79C4-12	THROAT PLATE WITH SCREW AND PIN	喉片組件
79C4-24	TAPERED & RELIEVED THROAT PLATE ASSEMBLY	喉盤組件
213C1-1	FIBRE SHIM	調整墊片
505C3-223	SMALL PLATE BASE COMPLETE 5"-8" KNIFE	小底盤(5-8"刀用)
505C3-224	LARGE PLATE BASE COMPLETE 9"-13" KNIFE	大底盤(9-13"刀用)
528C1-116	STANDARD (COMPLETE W/SLIDER, THROAT PLATE)	10"刀架組件
528C1-121	10" KNIFE(528C1-116) / 8" KNIFE(528C1-121)	8"刀架組件
532C2-5	RUBBER MOUNTED ROLLER (COMPLETE)	膠輪
619C1-31	ROLLER SHELL (COMPLETE)	滑輪
643C1-43	KNIFE SLIDE (COMPLETE WITH SCREWS) 8"	刀夾(8"刀用)
643C1-47	KNIFE SLIDE (COMPLETE WITH SCREWS) 10"	刀夾(10"刀用)
529C1-8	KNIFE BOLT WRENCH	刀片螺栓套筒扳手
95C5-3	ALLEN WRENCH FOR SHOE SET SCREW	六角扳手
242C2-2	BEARING GREASE	軸承油脂
162C2	OIL CAN	油罐
81C1-2	SLOT CLEANSE	清槽工具
181C2-2 SP	ABRASINE BELTS	砂布帶
508C1-100	TREMINAL BLOCK	插座組
523C1-100	ATTACHMENT PLUG	插頭組

# CUTTING MACHINE SPARE PARTS

EASTMAN裁布機零件系列 FOR EASTMAN SERIES

## Single-Phase Motor Assemblies

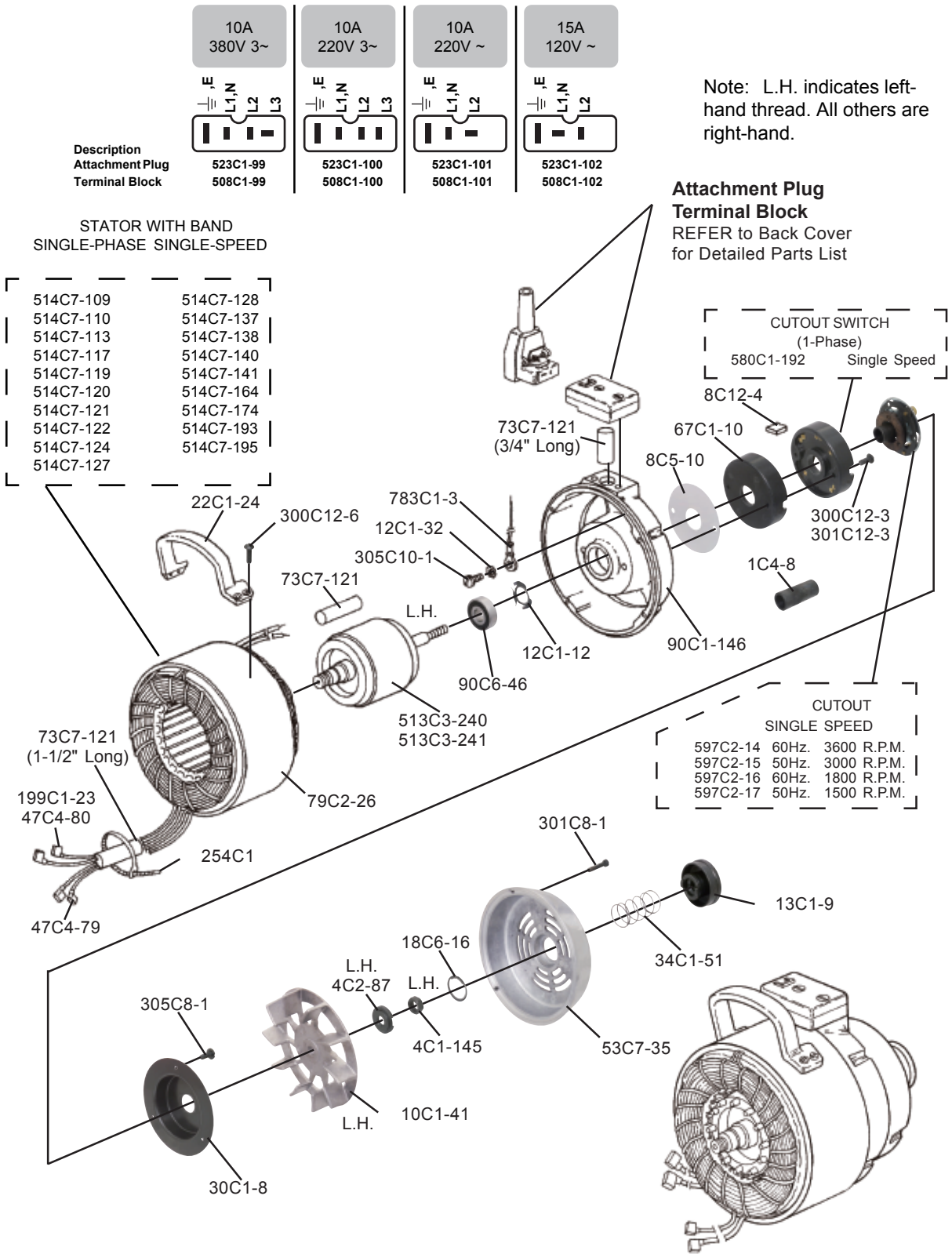

# CUTTING MACHINE SPARE PARTS

## FOR EASTMAN SERIES EASTMAN裁布機零件系列

### Front Bearing Housing with Oiler Assembly

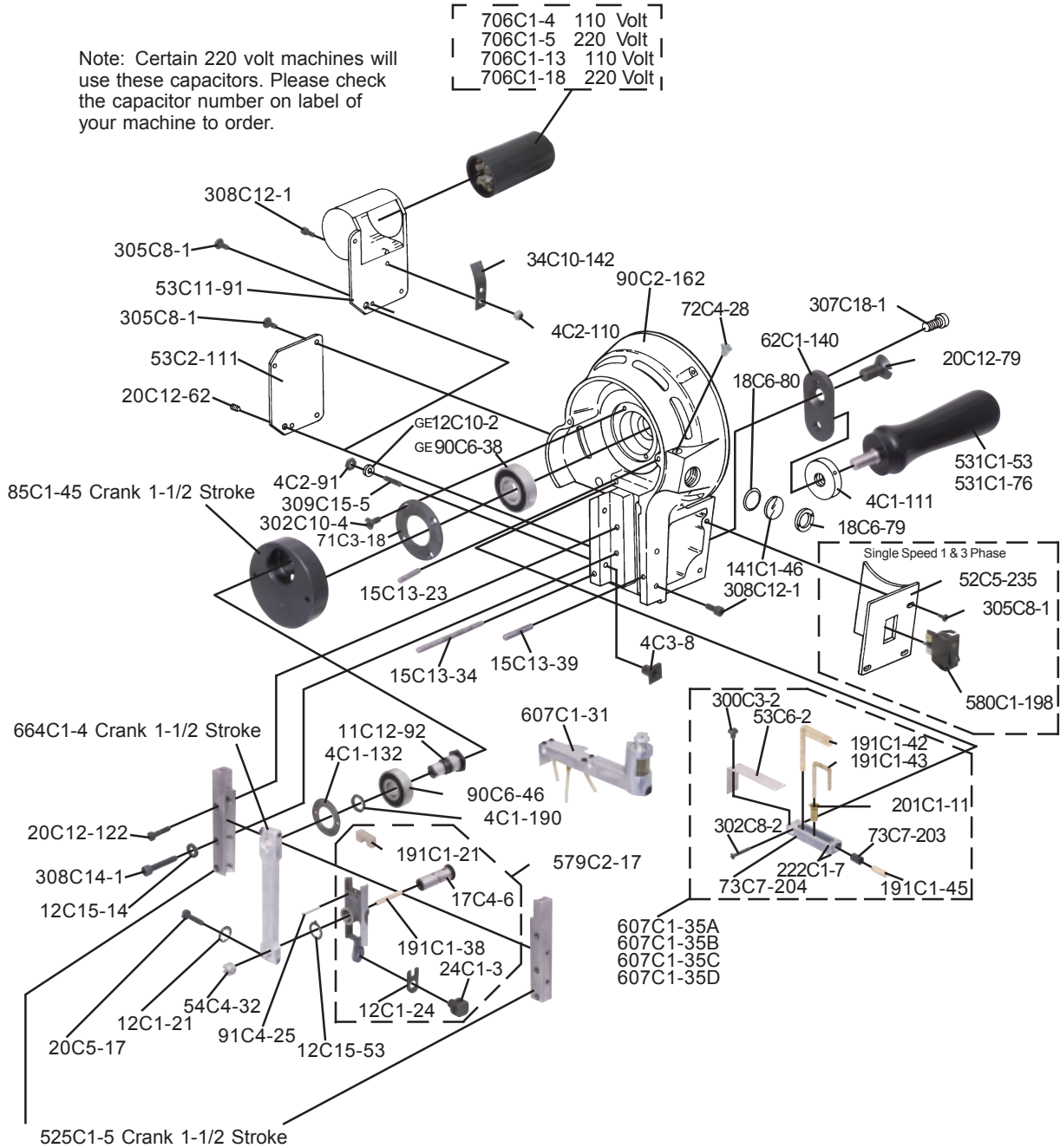

Notes: L.H. indicates left-hand thread. All others are right-hand.

Slip large lug over switch before replacing switch base. Secure switch to base tightly to ensure positive ground.



# CUTTING MACHINE SPARE PARTS

EASTMAN裁布機零件系列 FOR EASTMAN SERIES

## Sharpener Housing Assembly

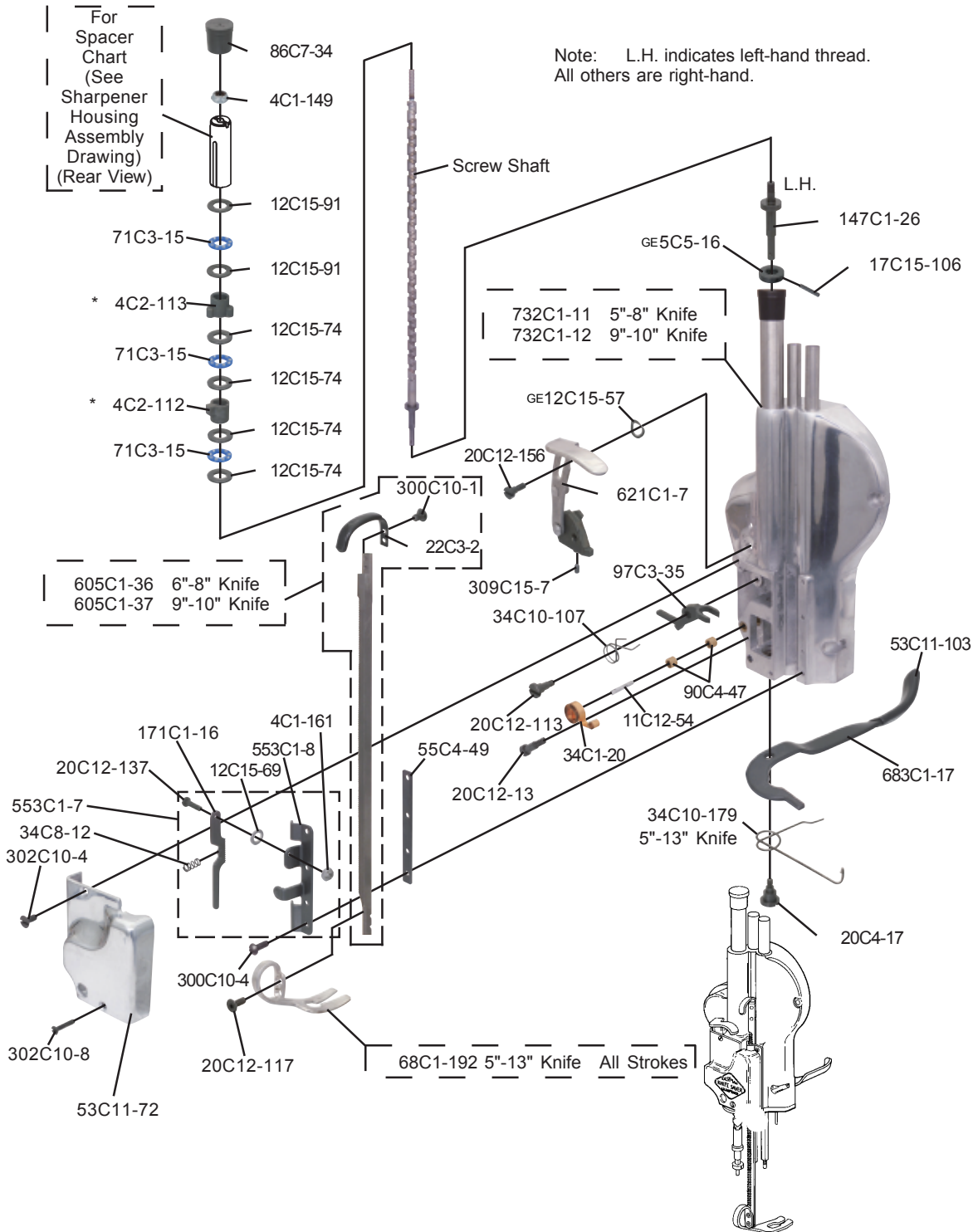

# CUTTING MACHINE SPARE PARTS

FOR EASTMAN SERIES EASTMAN裁布機零件系列

## Sharpener Housing Assembly

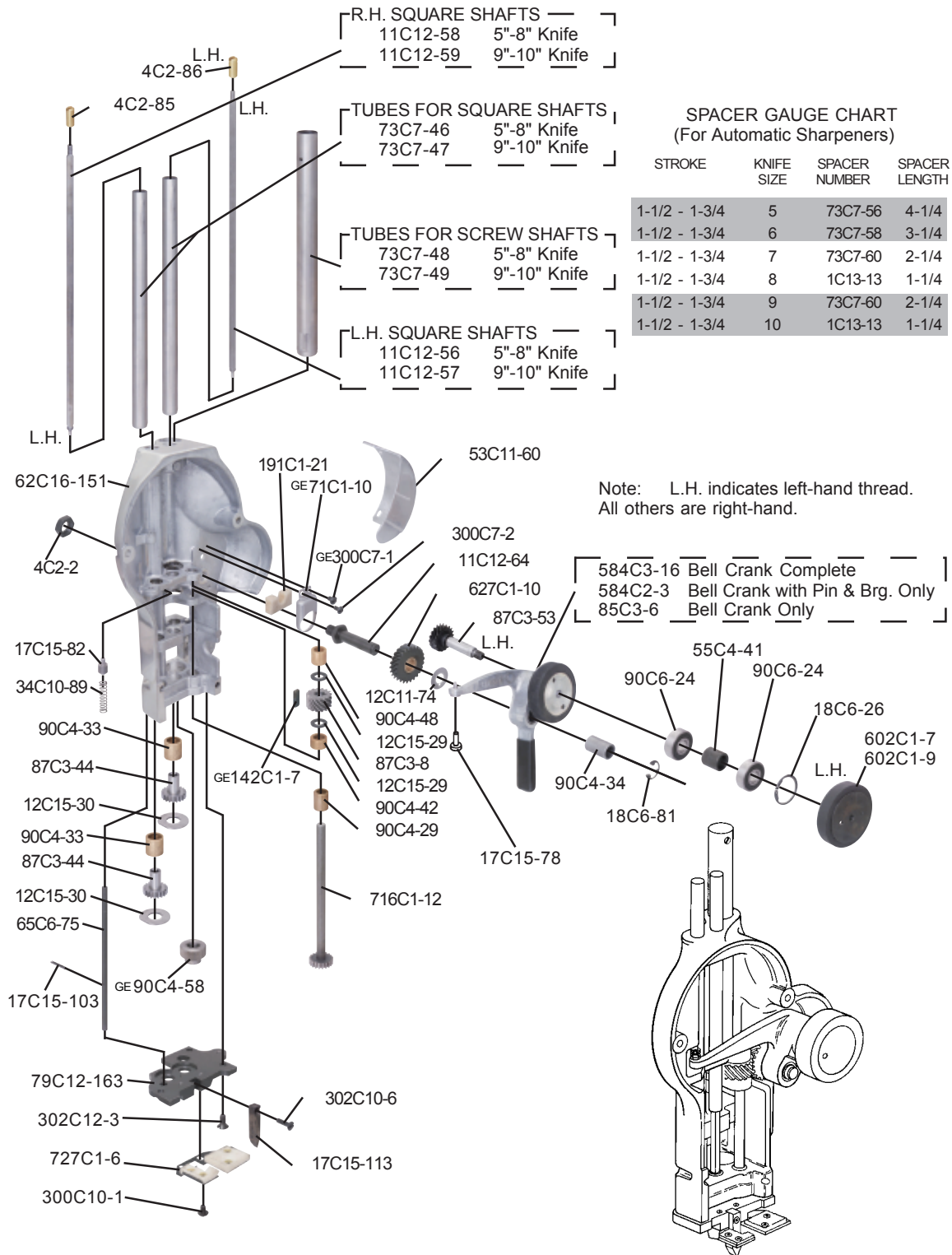

# CUTTING MACHINE SPARE PARTS

EASTMAN 裁布機零件系列 FOR EASTMAN SERIES

## Lower Gear Bracket Assembly

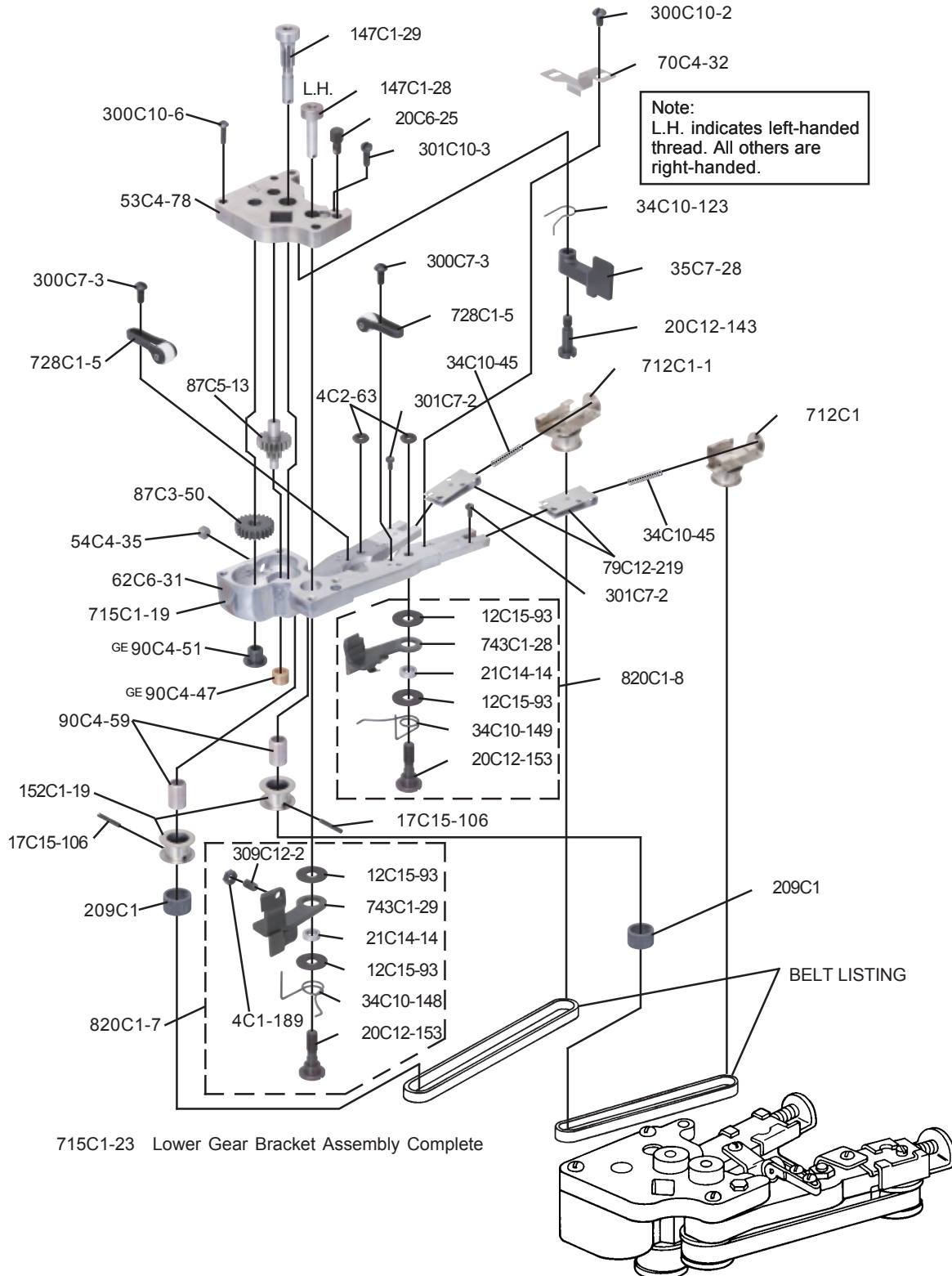

# CUTTING MACHINE SPARE PARTS

FOR K M SERIES K M裁布機零件系列

## Standard and Baseplate Assembly

STANDARDS COMPLETE W/SLIDES	
528C1-121	8" Standard
528C1-116	10" Standard

### INSTRUCTIONS FOR REMOVING WORN PLATE ROLLER SHELL

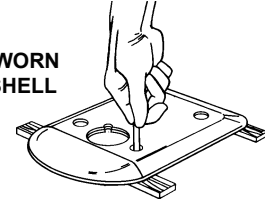

Removing a Worn Plate Roller Shell

#### KNIFE SLIDES

643C1-43	8" Knife
643C1-47	10" Knife

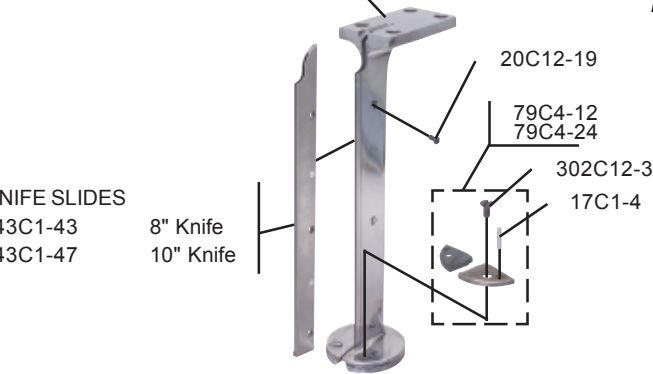

NOTE: A roller shell (complete with shaft and bearings) may be ordered as required. Specify part number GE619C1-30.

To install a new roller shell, invert the baseplate and press the roller shell into the ring assembly.

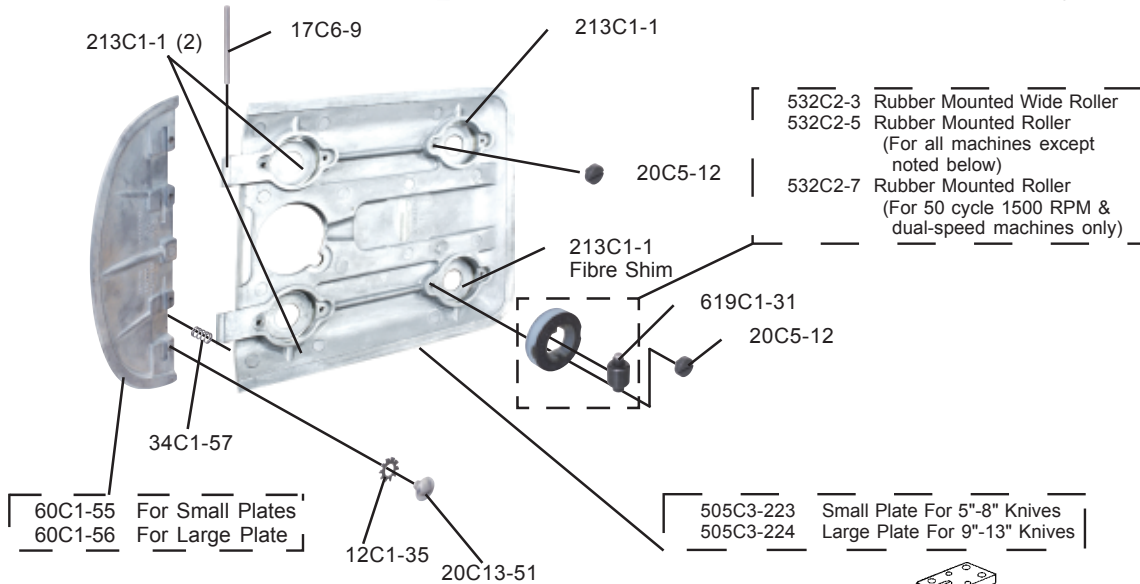

532C2-3	Rubber Mounted Wide Roller
532C2-5	Rubber Mounted Roller (For all machines except noted below)
532C2-7	Rubber Mounted Roller (For 50 cycle 1500 RPM & dual-speed machines only)

60C1-55	For Small Plates
60C1-56	For Large Plate

505C3-223	Small Plate For 5"-8" Knives
505C3-224	Large Plate For 9"-13" Knives

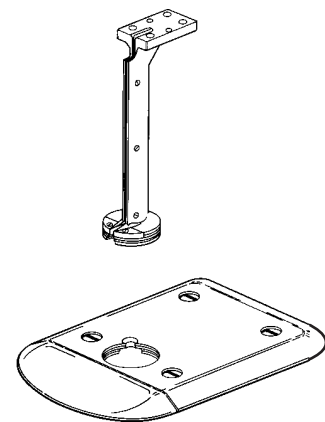



[www.wayken.com.tw](http://www.wayken.com.tw)

STRAIGHT KNIVES  
ROUND KNIVES  
OVERLOCK KNIVES  
TRIMMING BLADES  
BUTTON HOLE KNIVES  
BINDER & HEMMER FEET  
SCISSORS & CLIPPERS  
TOOLS & ACCESSORIES  
SPARE PARTS FOR EASTMAN, KM CUTTING MACHINE

偉群製刀工業股份有限公司(台灣)  
GREAT KNIVES MANUFACTURE CO., LTD  
Head Office (Taiwan)  
248新北市五股區五工三路115號  
NO, 115 Wugong 3rd Road, Wugu District,  
New Taipei City 248, Taiwan(R.O.C.)  
TEL: +886 2 2299-1297  
FAX: +886 2 2299-1298  
[www.greatknives.com.tw](http://www.greatknives.com.tw)

偉群金屬工業(昆山)有限公司  
Great Industrial (Kunshan) Co., Ltd.  
江蘇省昆山市陸家鎮金陽東路6號  
No.6 Jin Yang East Road., Lu Jan Town,  
Kunshan, Jiangsu China  
TEL : 86-512-57075016 57079888  
FAX : 86-512-57079922

